

NOT RECOMMENDED FOR NEW DESIGNS

* For new designs please see part numbers: FR05DxDXDR

FM05DHIR FM05DVIR DC-5 MBd Dual Supply Voltage RedLink® Receiver



Preliminary Data Sheet



DESCRIPTION

The Firecomms DC to 5 MBd Dual supply voltage RedLink® receiver is based on a fully integrated photo-diode with TIA and limiting amplifier. Housed in non-conducting plastic RedLink® connector housings, the receiver is blue in colour. The housing is compatible with the Versatile Link style fiber plug, and is designed primarily for use with Plastic Optic Fiber (POF).

The receiver operates equally at both the standard 3.3 V and 5 V DC supply rail voltages. It operates over the industrial temperature range of -40 °C to +85 °C supporting many industrial applications where a reliable command and control response is required in electrically harsh environments.

The receiver uses integrated light detection and amplification in a single piece of silicon giving enhanced immunity to EMI/EMC from the local environment making the unit ideal for use in electrically noisy applications. The receiver has a single push-pull logic output compatible to TTL/CMOS.

NOTE: Applications switching 12V/15V should use p/n: FM20VHIR. Applications that require an Open-Collector to 5V should use p/n: FM05MHCR.

AVAILABLE OPTIONS

Table 1
ORDERING INFORMATION / PART NUMBERS

5 MBd Horizontal Package Inverting, TTL	FM05DHIR
5 MBd Vertical Package Inverting, TTL	FM05DVIR

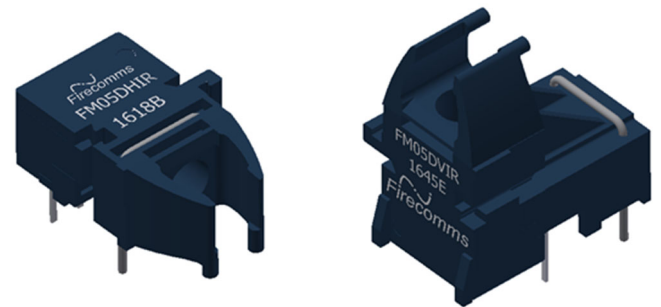

FEATURES

- Designed for use with Plastic Optic Fiber (POF)
- Optimized for data transmission from DC-5 MBd
- Industrial Temperature Range -40 °C to +85 °C
- Dual 5 V and 3.3 V power supply operation
- RoHS compliant and flame retardant (UL 94 V-0) housing
- Horizontal and Vertical options available
- Push Pull TTL Compatible CMOS output
- Low pulse width distortion
- Compatible with Versatile Link cables and connectors

APPLICATIONS

Table 2
APPLICATIONS

Application	Automation and Industrial Control. Serial Communications. Voltage Isolation.
Standard	Serial RS232, RS485, CAN-Bus, MODBUS, Profibus
Distance	50 meters Step Index POF ^[1] 300 meters with 200 µm PCS fiber ^[1]
Speed	DC to 5 MBd

Note: 1 Depending on the installation conditions

SPECIFICATIONS

Table 3
RECEIVER PIN DESCRIPTION

Pin	Name	Symbol
1	Receiver Output	V_o
2	Receiver Ground	GND
3	Receiver VCC	VCC
4	No Connect	N/C
5	Retaining Pin	GND
8	Retaining Pin	GND

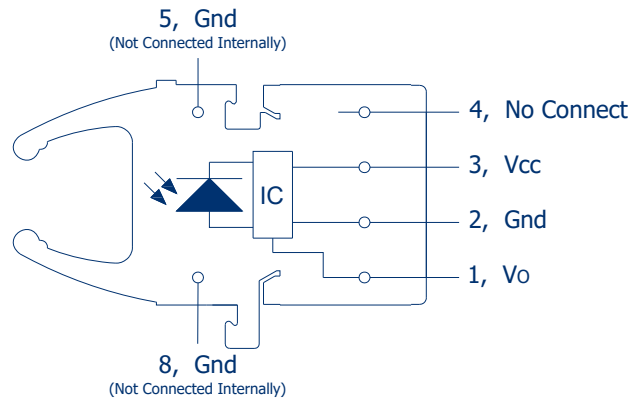

FIGURE 1
Receiver pin-out, top view.

Table 4
REGULATORY COMPLIANCE

Parameter	Symbol	Standard	Level
Electrostatic Discharge, Human Body Model (contact ESD)	HBM	Mil-STD-883	Level 2 (4 kV)
UL Certification	UL	94 V-0	Files No. (Pending)
Storage Compliance	MSL	J-STD-020D	2a (4-week floor life)
Restriction of Hazardous Substances Directive	RoHS	Directive 2011/65/EU	Certified compliant
Eye Safety		IEC 60825-1	LED Class 1

RECOMMENDED APPLICATION CIRCUIT

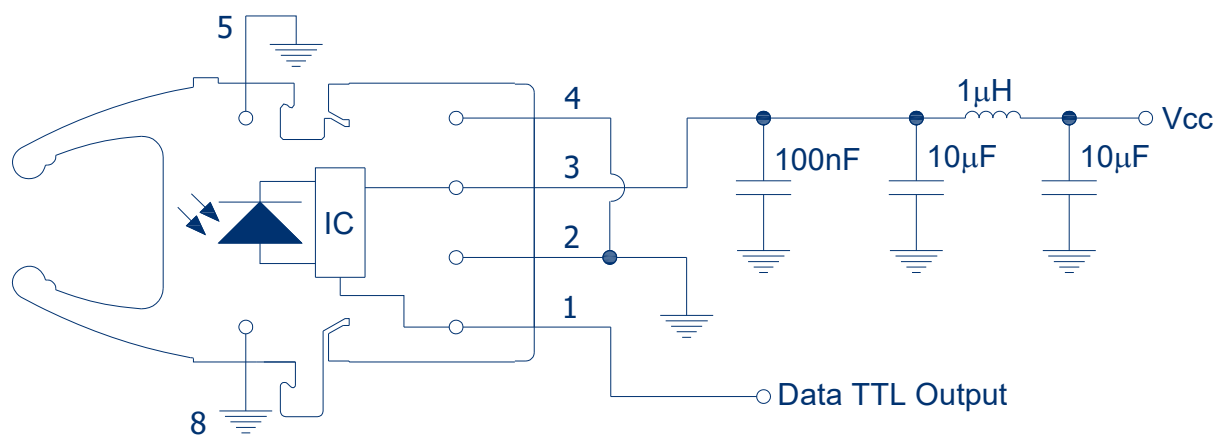

FIGURE 2
Recommended receiver application circuit. See notes 8, 9 Table 6.

SPECIFICATIONS

Table 5
ABSOLUTE MAXIMUM RATINGS

These are the absolute maximum ratings at or beyond which the FOT can be expected to be damaged.

Notes:

1. 260°C for 10 seconds, one time only, at least 2.2 mm away from lead root.

Parameter	Symbol	Minimum	Maximum	Unit
Storage Temperature	T_{stg}	-40	+85	°C
Operating Temperature	T_{op}	-40	+85	°C
Soldering Temperature ^[1]	T_{sld}		+260 ^[1]	°C
Supply Voltage	Vcc	-0.5	5.5	V
RX Output Current	I_o		+25	mA
Storage Compliance	MSL		2a	J-STD-020D

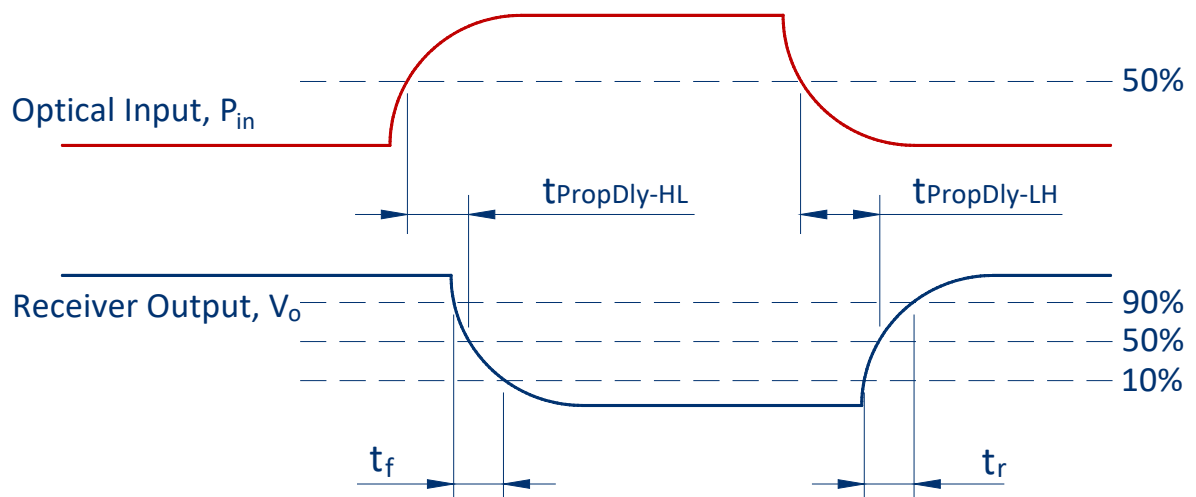

FIGURE 3
Receiver Propagation Delay and rise/fall time definitions as per application circuit of Figure 2.

This Receiver has an output stage that is a standard CMOS push-pull design. It is suitable for operation with standard 5V and 3.3V CMOS logic IC's. It is not an open collector stage. It is not compatible with voltages higher than 5.5 V. If an open collector option is required to switch voltages in the range 5.5 to 3 V then please select part number FM05DHCR.

If an open collector option is required to switch for example 12 or 15 V (range: 3 to 20 V) please select for example part number FM20VHIR which has an integrated MOSFET dedicated for this operation.

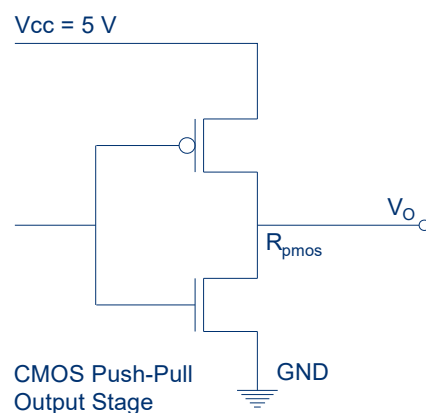

FIGURE 4
Receiver CMOS Push-Pull output stage.

SPECIFICATIONS

Table 6
RECEIVER ELECTRICAL AND OPTICAL CHARACTERISTICS

Test Conditions:

1. *Wake up Delay is the delay from VCC > 2.75 V to when the output will respond correctly to optical input. Output is held in tristate before this time.*
2. *Test data was validated over the full temperature range of -40 °C to +85 °C, and over both supply rail voltage options of 5 V and 3.3 V ± 10% and over the input optical received power as specified by P_H and P_L. Input power levels are for peak (not average) optical input levels. For 50% duty cycle data, peak optical power is twice the average optical power. Data referred to as typical are rated at +25 °C.*
3. *Testing in the recommended receiver circuit (R_L= 50 kΩ, C_{L(total)}= 15 pF)*
4. *Optical signal from the recommended Transmitter circuit.*
5. *PWD for Optical Input of 5 MBd, NRZ 2⁷-1 (PRBS7) data, resulting in a BER ≤ 10⁻⁹.*
6. *For an Optical Power High (OPH) range of -20 to + 2 dBm the Pulse Width Distortion (PWD) is ± 4 ns*
7. *If data rate < 1 MBd, then the pulse width distortion = PWD 1st to 3rd pulse.*
8. *Pins 5 and 8 are used for mounting and retaining purposes. It is recommended that pins 5 and 8 be connected to ground.*
9. *Pin 4 is electrically isolated internally. Pin 4 may be externally connected to pin 1 for board layout compatibility with existing designs. Otherwise it is recommended pin 4 be grounded as in Figure 3.*

Parameter	Symbol	Min	Typical	Max	Unit	Test Condition
Supply Current	I _{CC}		13	16	mA	[2,3,4]
Wake Up Delay (power up)	t _{power-on}		40		µs	[1]
High Level Output Voltage	V _{OH}	V _{CC} – 0.05		V _{CC}	V	I _{OH-max} = 40 µA, [2]
Low Level Output Voltage	V _{OL}	0		0.1	V	I _{OL-max} =1.6 mA, [2]
POF Optical Power High	P _H	-22		+2	dBm	[2,3], 1mm 0.5 NA POF
POF Optical Power Low	P _L			-40	dBm	[2,3], 1mm 0.5 NA POF
PCS Optical Power High	P _H	-24		+2	dBm	[2,3], 200 µm PCS
PCS Optical Power Low	P _L			-42	dBm	[2,3], 200 µm PCS
Data Rate		DC		5	Mbd	Min UI = 200 ns, Max f = 2.5 MHz
Output Rise Time (10 % - 90 %)	t _r	4	8	12	ns	[2,3,4]
Output Fall Time (90 % - 10 %)	t _f	4	9	13	ns	[2,3,4]
Pulse Width Distortion	PWD	-10		+10	ns	[2,3,5,6]
Pulse Width Distortion 1 st to 3 rd pulse	PWD _{init}	-10		+12	ns	[2,3,7]
Propagation Delay	t _{PropDly-HL}			45	ns	[2,3,5,7]
	t _{PropDly-LH}			45	ns	[2,3,5,7]

MECHANICAL DATA, HORIZONTAL

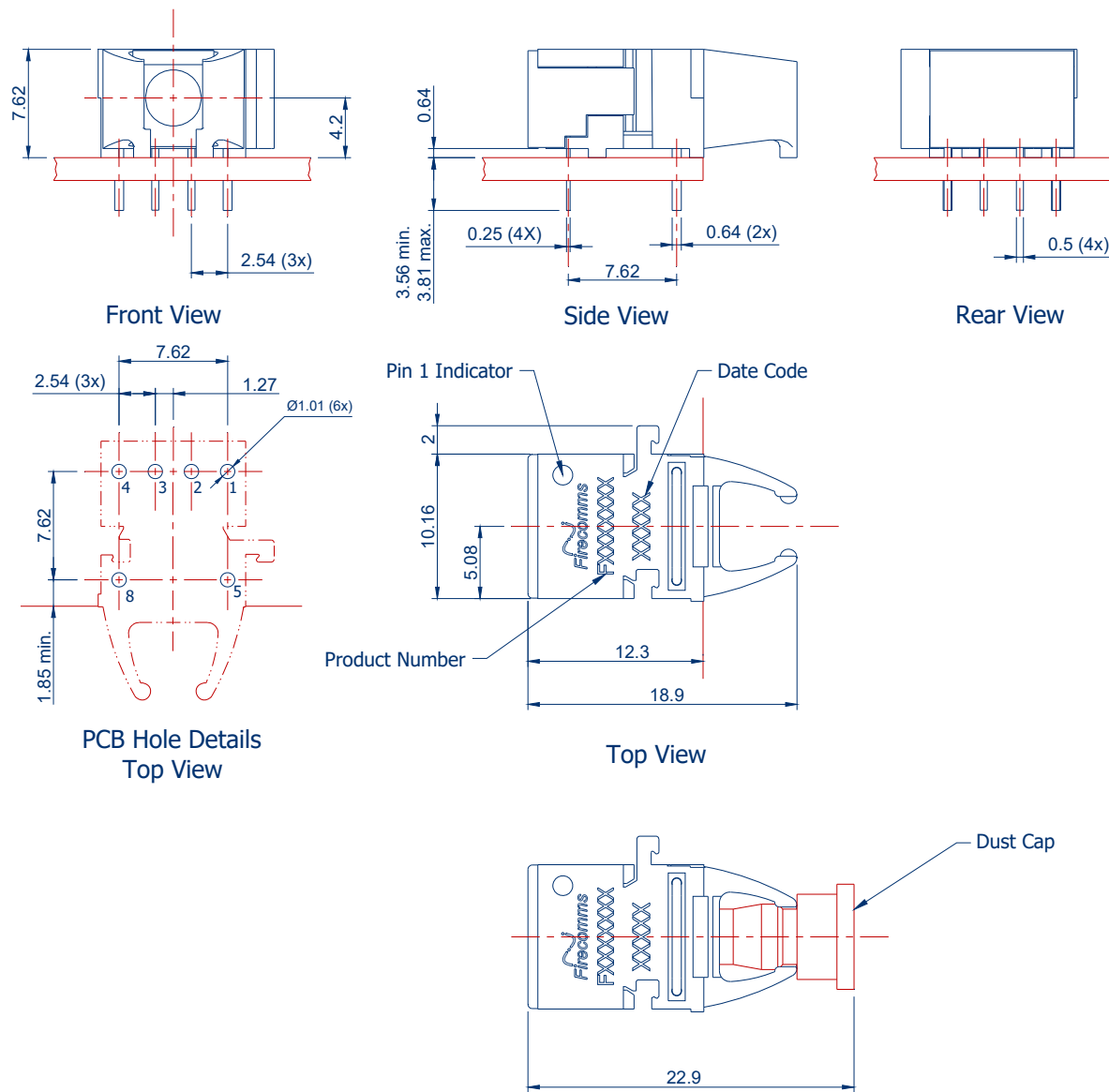

FIGURE 5
Mechanical dimensions of the horizontal receivers and PCB footprint, which is a top view.
General dimensional tolerance is ± 0.2 mm

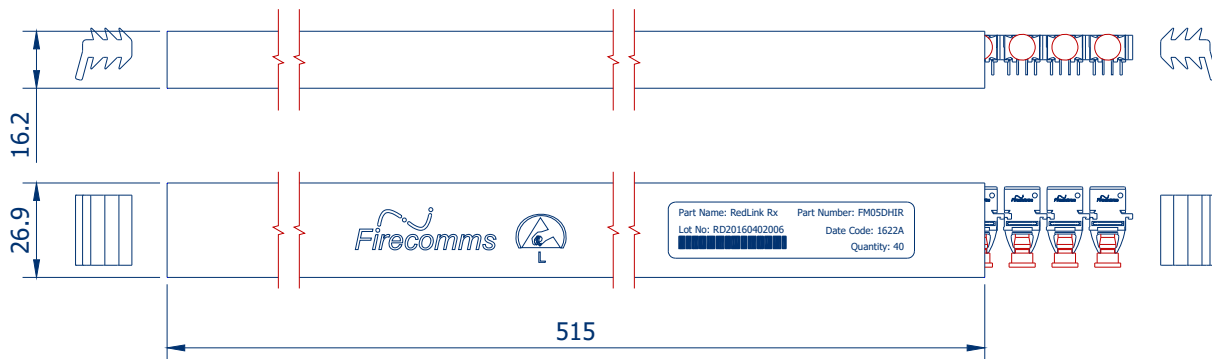

FIGURE 6
Packing tube for Firecomms Horizontal RedLink® Receivers

MECHANICAL DATA, VERTICAL

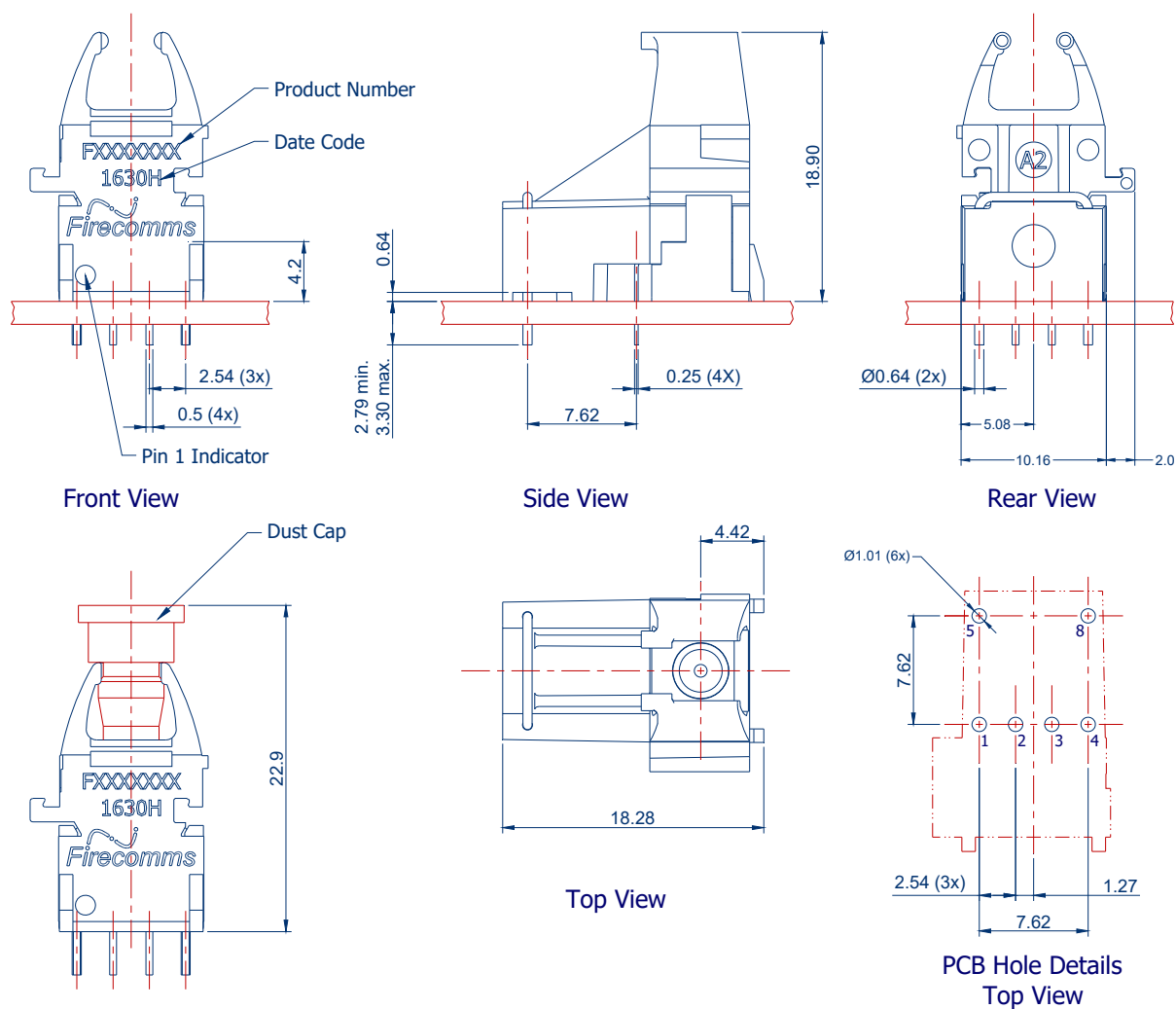

FIGURE 7
 Mechanical dimensions of the vertical receivers and PCB footprint, which is a top view.
 General dimensional tolerance is ± 0.2 mm

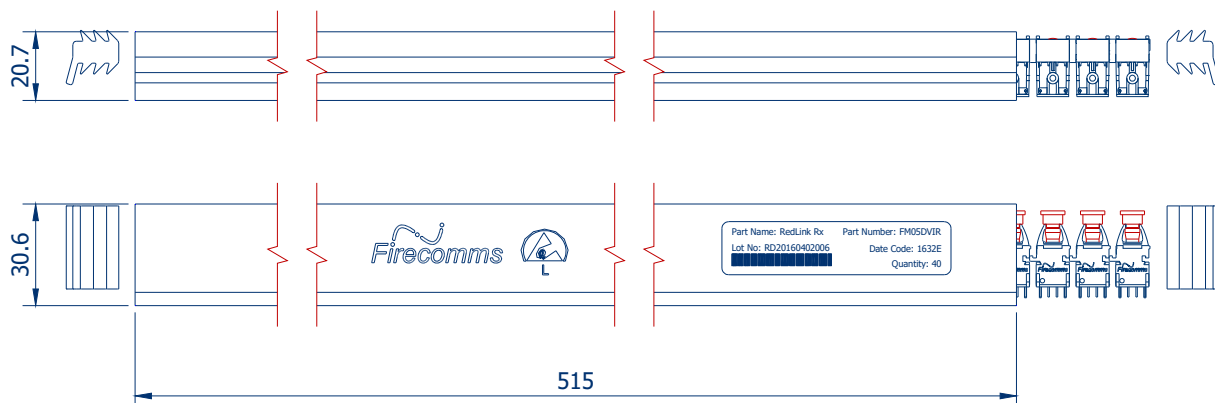

FIGURE 8
 Packing tube for Firecomms Vertical RedLink® Receivers

PART HANDLING

Firecomms' 5 MBd RedLink® devices are color coded, receivers are blue, transmitters are gray. They are auto-insertable. They are tested for handling in static-controlled assembly processes (HBM). Cleaning, degreasing and post solder washing should be carried out using standard solutions compatible with both plastics and the environment. For example, recommended solutions for degreasing are alcohols (methyl, isopropyl and isobutyl). Acetone based products are not permitted.

In the soldering process, non-halogenated water soluble fluxes are recommended. RedLink® products are not suitable for use in reflow solder processes (infrared/vapor-phase reflow). The dust plug should remain in place during soldering, washing and drying processes to avoid contamination of the active optical area of each part.

The Moisture Sensitivity Level (MSL) classification of this device is 2a according to JEDEC J-STD-020E. The shelf life of an unopened MBB (Moisture Barrier Bag) is 24 months at < 40 °C and < 90 % R.H. Once the Moisture Barrier Bag is opened the devices can be either

- a) Stored in normal factory conditions < 30 °C and < 60 % R.H. for a maximum of 672 hours (4 Weeks) prior to soldering.
- b) Stored at < 10 % R.H. (Dry Cabinet).

PACKING INFORMATION

Components are packed in PVC anti-static tubes in moisture barrier bags. Bags should be opened only in static-controlled locations, and standard procedures should be followed for handling moisture sensitive components.

Table 7
PACKING INFORMATION

	Horizontal	Vertical
Components per Tube	40	40
Tube Length	515 mm	515 mm
Tube Height	16.2 mm	21.0 mm
Tube Depth	26.9 mm	30.8 mm
Tubes per Bag	5	5
Bags per Inner Carton	1	1
Inner Carton Length	630 mm	630 mm
Inner Carton Width	70 mm	70 mm
Inner Carton Height	105 mm	105 mm
Weight per Inner Carton, Complete	0.77 kg	0.92 kg
Components per Inner Carton	200	200
Inner Cartons per Outer Carton	10	10
Outer Carton Length	650 mm	650 mm
Outer Carton Width	235 mm	235 mm
Outer Carton Height	376 mm	376 mm
Weight per Outer Carton, Complete	8.14 kg	9.59 kg
Components per Outer Carton	2,000	2,000

For the most recent revision or further information please visit www.firecomms.com or contact the company directly at the following address, Firecomms Ltd, 2200 Airport Business Park, Cork, IRELAND. Copyright© 2004-2016 Firecomms. All rights reserved. Firecomms refers to Firecomms Limited and/or its subsidiaries. Firecomms assumes no responsibility for inaccuracies or omissions in the information contained in this document. Specifications are subject to change without notice. No patent rights are granted to any of the circuits described herein.